



**ROGERS SPRAYERS INC.**

141 - 105th Street East  
Saskatoon, SK S7N 1Z2  
Canada

Phone: (306) 975-0500  
Fax: (306) 975-0499  
Email: [info@rogerssprayers.com](mailto:info@rogerssprayers.com)  
Web: [www.rogerssprayers.com](http://www.rogerssprayers.com)

# WG6 Windfoil Greensap 6-ft Covered Hose-fed Sprayer



## Assembly, Parts and Operator's Manual

Version WG-1007

# Table of Contents

<b>SAFETY</b> .....	<b>3</b>
Operational Safety .....	3
<b>GENERAL SPRAYING INFORMATION</b> .....	<b>3</b>
Application Tips .....	3
Nozzles .....	4
Diaphragm Check Valve Nozzle Bodies.....	4
Calibration .....	4
Application Rate Table, 12” spacing .....	5
<b>GENERAL MAINTENANCE</b> .....	<b>7</b>
Cleaning .....	7
Sunshine .....	8
Winterizing.....	8
<b>ASSEMBLY</b> .....	<b>8</b>
Front Wheel Installation .....	8
Handle attachment .....	8
Hose attachment .....	8
Last Check .....	8
<b>OPERATION</b> .....	<b>9</b>
<b>MAINTENANCE</b> .....	<b>9</b>
<b>DRAWINGS AND REPLACEMENT PARTS</b> .....	<b>9</b>
WG Parts Breakdown.....	10
Plumbing Assembly .....	11
Flowmonitor Assembly.....	12
Valve Handle Assembly .....	13
Tow Hitch (optional).....	13
CE Declaration of Conformity.....	14

# Safety

---

Many people die or suffer serious injury in job related accidents every year due to carelessness. Know your machinery and be aware of potential hazards. Put safety first in all your operations.

Review all instructions and procedures outlined in this manual annually. Every operator must familiarize himself with the operating instructions of the sprayer.

## Operational Safety

Shut down sprayer and power unit and wait for all parts to stop before adjusting, cleaning, or lubricating the power unit or sprayer.

Before spraying a field familiarize yourself with any rocks, debris, trees, ditches or gullies that may be potentially dangerous. Plan the spraying route to avoid these hazards.

Spray only chemicals that unit was designed for, (ie turf application). Do not use products for which unit was not designed, (ie PAINT, sealants, cleaning fluids, dust inhibitors, ice surfaces).

### Minimize Chemical Drift

The **Windfoil** sprayer was designed in a wind tunnel to control air flow around and behind the sprayer minimizing drift to allow safer spraying in windy conditions.

Drift can blow off a field after it has been sprayed, especially in high winds. Reasonable caution should be taken in order to spray effectively and safely.

**For maximum drift control, keep curtain in contact with the ground to ensure a seal to it. Drift control of the *Windfoil* is less effective when the wind blows the curtain off the crop canopy breaking the seal between the curtain and the crop.**

## General Spraying Information

---

### Application Tips

Always use clean filtered water in the sprayer tank.

Your **Windfoil** Drift Containment Spray System (DCSS) comes standard with ceramic insert tips. These tips are considered by most to be the best in the industry for wear resistance and spray pattern coefficient of variation. Please contact your manufacturer for various sizes of tips available for your machine.

Ensure that the pressure on the supply end of the hose used on hose reels is sufficient to deliver the proper pressure at the hand unit on the delivery end of the hose.

Check the flow rate from all nozzles using the capacity calibration technique; see the Calibration section for tables and instructions. Use clean filtered water for all calibration testing. Adjust the sprayer pressure to get the proper flow rate. The flow meters are not accurate enough in absolute terms to be used as a flow meter. In relative terms they are very accurate.

<b>Caution:</b>	Conventional tips are rated at 40 psi (3 bar), for example a 8004 tip at 40 psi (3 bar) delivers 0.4 US gal/min (1.5 litres/min) . Only conventional 80° tips are recommended for the <b>Windfoil WG</b> series. Wider angle tips (110°) have a wider pattern than 80° and will hit the curtain at the ends of the boom and are
-----------------	---

## Nozzles

Despite being the most important component for accurate uniform spraying application, nozzles are often neglected and abused.

Nozzle flow rate depends on effective orifice size and pressure. Spray tip manufacturers have supplied tables of nozzle application rates at various pressures, for the best results it is recommended that you follow these guidelines.

The rule of thumb is that as you increase the pressure to your unit the average droplet size decreases. Normally with conventional open boom sprayers large droplets are used to control drift but large droplets can roll off plants without sticking. With the **Windfoil** covered spray system you will be able spray with smaller droplets, increase coverage and not worry about drift.

The spray patterns must overlap for even coverage but should not interfere with one another. Nozzles are set at a 10° angle so that one edge of its pattern will be just behind the edge of its adjacent spray pattern, evading interference with each other.

Typically as a tip wears the spray pattern distorts output volumes usually increase and the droplet characteristics change. Recalibration may correct for output changes, but cannot correct for spray pattern changes or the drop size generated.

<p><b>Caution:</b> When spraying next to a flower bed, do not spray over the turf edge as the spray will go under the curtain and onto the flowers.</p>
---

## Diaphragm Check Valve Nozzle Bodies

Diaphragm check valves close at approximately 15 psi (1 bar) to prevent excessive dripping. Should the cap on the valve loosen or the check valve diaphragm become misaligned, the body may leak. Stop the leak by, tightening the check valve cap or remove the cap and inspect the seal for damage or improper assembly.

To check for defective check valves when the spraying stop control has been actuated, the volume that drips from each nozzle should not exceed 2ml timed over a 5 minute period. The measuring is to start 8 seconds after the flow to the spray boom is shut off.

Nozzle caps are attached by engaging the cap and turning clockwise about a third of a turn. Self-aligning caps have a slot to align the tips. Ensure that the tips fit down into the slotted hole before installing caps on the diaphragm nozzle body assembly with the tip screens.

Non-aligning caps are also available for special tips.

## Calibration

As a tip wears recalibration may be required. Collect the output from each nozzle for 60 seconds, using an accurate measuring cup. Use clear water for all testing. Record the output from each nozzle. Replace nozzles that are more than 5% above or below the average reading, or has a visibly distorted pattern.

## Application Rates, 12" Spacing

### 80 Deg. Tips

Rogers Part #	Tip Number	Liquid Press psi	Capacity 1 nozzle gpm	U. S. GALLONS PER ACRE					U. S. GALLONS PER 1000 SQ. FT.					Press bars
				2.5	3	4	5	7	2.5	3	4	5	7	
				mph	mph	mph	mph	mph	mph	mph	mph	mph	mph	
05872	800067SS (200 mesh)	30	0.058	11.5	9.6	7.2	5.7	4.1	0.26	0.22	0.16	0.13	0.09	2.07
		40	0.067	13.3	11.1	8.3	6.6	4.7	0.30	0.25	0.19	0.15	0.11	2.76
		50	0.075	14.8	12.4	9.3	7.4	5.3	0.34	0.28	0.21	0.17	0.12	3.45
		60	0.082	16.2	13.5	10.2	8.1	5.8	0.37	0.31	0.23	0.19	0.13	4.14
01369	8001VS (100 mesh)	30	0.087	17.1	14.3	10.7	8.6	6.1	0.39	0.33	0.25	0.20	0.14	2.07
		40	0.100	19.8	16.5	12.4	9.9	7.1	0.45	0.38	0.28	0.23	0.16	2.76
		50	0.112	22.1	18.4	13.8	11.1	7.9	0.51	0.42	0.32	0.25	0.18	3.45
		60	0.122	24.2	20.2	15.2	12.1	8.7	0.56	0.46	0.35	0.28	0.20	4.14
00827 13351	80015VS or API-80015 (100 mesh)	30	0.130	25.7	21.4	16.1	12.9	9.2	0.59	0.49	0.37	0.29	0.21	2.07
		40	0.150	29.7	24.8	18.6	14.9	10.6	0.68	0.57	0.43	0.34	0.24	2.76
		50	0.168	33.2	27.7	20.8	16.6	11.9	0.76	0.63	0.48	0.38	0.27	3.45
		60	0.184	36.4	30.3	22.7	18.2	13.0	0.83	0.69	0.52	0.42	0.30	4.14
05876 14384	8002VS or AXI-8002 (50 mesh)	30	0.173	34.3	28.6	21.4	17.1	12.2	0.79	0.65	0.49	0.39	0.28	2.07
		40	0.200	39.6	33.0	24.8	19.8	14.1	0.91	0.76	0.57	0.45	0.32	2.76
		50	0.224	44.3	36.9	27.7	22.1	15.8	1.01	0.84	0.63	0.51	0.36	3.45
		60	0.245	48.5	40.4	30.3	24.2	17.3	1.11	0.93	0.69	0.56	0.40	4.14
05877 14385	8003VS or AXI-8003 (50 mesh)	30	0.260	51.4	42.9	32.2	25.7	18.4	1.18	0.98	0.74	0.59	0.42	2.07
		40	0.300	59.4	49.5	37.1	29.7	21.2	1.36	1.13	0.85	0.68	0.49	2.76
		50	0.335	66.4	55.3	41.5	33.2	23.7	1.52	1.27	0.95	0.76	0.54	3.45
		60	0.367	72.7	60.6	45.5	36.4	26.0	1.67	1.39	1.04	0.83	0.59	4.14
05878 14061	8004VS or AXI-8004 (50 mesh)	30	0.346	68.6	57.2	42.9	34.3	24.5	1.57	1.31	0.98	0.79	0.56	2.07
		40	0.400	79.2	66.0	49.5	39.6	28.3	1.81	1.51	1.13	0.91	0.65	2.76
		50	0.447	88.5	73.8	55.3	44.3	31.6	2.03	1.69	1.27	1.01	0.72	3.45
		60	0.490	97.0	80.8	60.6	48.5	34.6	2.22	1.85	1.39	1.11	0.79	4.14
05879 14386	8005VS or AXI-8005 (50 mesh)	30	0.433	85.7	71.4	53.6	42.9	30.6	1.96	1.64	1.23	0.98	0.70	2.07
		40	0.500	99.0	82.5	61.9	49.5	35.4	2.27	1.89	1.42	1.13	0.81	2.76
		50	0.559	110.7	92.2	69.2	55.3	39.5	2.53	2.11	1.58	1.27	0.91	3.45
		60	0.612	121.2	101.0	75.8	60.6	43.3	2.78	2.31	1.74	1.39	0.99	4.14
05880 14387	8006VS or AXI-8006 (50 mesh)	30	0.520	102.9	85.7	64.3	51.4	36.7	2.36	1.96	1.47	1.18	0.84	2.07
		40	0.600	118.8	99.0	74.3	59.4	42.4	2.72	2.27	1.70	1.36	0.97	2.76
		50	0.671	132.8	110.7	83.0	66.4	47.4	3.04	2.53	1.90	1.52	1.09	3.45
		60	0.735	145.5	121.2	90.9	72.7	52.0	3.33	2.78	2.08	1.67	1.19	4.14
05881	8008VS (50 mesh)	30	0.693	137.2	114.3	85.7	68.6	49.0	3.14	2.62	1.96	1.57	1.12	2.07
		40	0.800	158.4	132.0	99.0	79.2	56.6	3.63	3.02	2.27	1.81	1.30	2.76
		50	0.894	177.1	147.6	110.7	88.5	63.2	4.05	3.38	2.53	2.03	1.45	3.45
		60	0.980	194.0	161.7	121.2	97.0	69.3	4.44	3.70	2.78	2.22	1.59	4.14
13674	MR8010 (50 mesh)	30	0.866	171.5	142.9	107.2	85.7	61.2	3.93	3.27	2.45	1.96	1.40	2.07
		40	1.000	198.0	165.0	123.8	99.0	70.7	4.53	3.78	2.83	2.27	1.62	2.76
		50	1.118	221.4	184.5	138.4	110.7	79.1	5.07	4.22	3.17	2.53	1.81	3.45
		60	1.225	242.5	202.1	151.6	121.2	86.6	5.55	4.63	3.47	2.78	1.98	4.14
14010	MR8015 (50 mesh)	30	1.299	257.2	214.3	160.8	128.6	91.9	5.89	4.91	3.68	2.94	2.10	2.07
		40	1.500	297.0	247.5	185.6	148.5	106.1	6.80	5.67	4.25	3.40	2.43	2.76
		50	1.677	332.1	276.7	207.5	166.0	118.6	7.60	6.34	4.75	3.80	2.72	3.45
		60	1.837	363.7	303.1	227.3	181.9	129.9	8.33	6.94	5.21	4.16	2.97	4.14
14195	MR8020 (50 mesh)	30	1.732	342.9	285.8	214.3	171.5	122.5	7.85	6.54	4.91	3.93	2.80	2.07
		40	2.000	396.0	330.0	247.5	198.0	141.4	9.07	7.56	5.67	4.53	3.24	2.76
		50	2.236	442.7	369.0	276.7	221.4	158.1	10.14	8.45	6.34	5.07	3.62	3.45
		60	2.449	485.0	404.2	303.1	242.5	173.2	11.10	9.25	6.94	5.55	3.97	4.14

## Application Rates, 12" Spacing

### **80 Deg. Tips**

Rogers Part #	Tip Number	Liquid Press psi	Capacity 1 nozzle gpm	U. S. GALLONS PER ACRE					Liters/Hectare (L/Ha)					Press bars	
				2.5	3	4	5	7	4	4.8	6.4	8	11.2		
				mph	mph	mph	mph	mph	kph	kph	kph	kph	kph		
05872	800067SS	30	0.058	11.5	9.6	7.2	5.7	4.1	107.42	89.52	67.14	53.71	38.36	0.28	
	(200 mesh)	40	0.067	13.3	11.1	8.3	6.6	4.7	124.04	103.36	77.52	62.02	44.30	0.33	
		50	0.075	14.8	12.4	9.3	7.4	5.3	138.68	115.56	86.67	69.34	49.53	0.37	
		60	0.082	16.2	13.5	10.2	8.1	5.8	151.91	126.59	94.95	75.96	54.25	0.40	
01369	8001VS	30	0.087	17.1	14.3	10.7	8.6	6.1	160.33	133.61	100.20	80.16	57.26	0.42	
	(100 mesh)	40	0.100	19.8	16.5	12.4	9.9	7.1	185.13	154.28	115.71	92.57	66.12	0.49	
		50	0.112	22.1	18.4	13.8	11.1	7.9	206.98	172.48	129.36	103.49	73.92	0.55	
		60	0.122	24.2	20.2	15.2	12.1	8.7	226.74	188.95	141.71	113.37	80.98	0.60	
00827	80015VS	30	0.130	25.7	21.4	16.1	12.9	9.2	240.49	200.41	150.31	120.25	85.89	0.63	
	or	40	0.150	29.7	24.8	18.6	14.9	10.6	277.70	231.41	173.56	138.85	99.18	0.73	
13351	API-80015	50	0.168	33.2	27.7	20.8	16.6	11.9	310.47	258.73	194.05	155.24	110.88	0.82	
	(100 mesh)	60	0.184	36.4	30.3	22.7	18.2	13.0	340.11	283.42	212.57	170.05	121.47	0.90	
05876	8002VS	30	0.173	34.3	28.6	21.4	17.1	12.2	320.65	267.21	200.41	160.33	114.52	0.85	
	or	40	0.200	39.6	33.0	24.8	19.8	14.1	370.26	308.55	231.41	185.13	132.24	0.98	
	14384	AXI-8002	50	0.224	44.3	36.9	27.7	22.1	15.8	413.96	344.97	258.73	206.98	147.84	1.09
		(50 mesh)	60	0.245	48.5	40.4	30.3	24.2	17.3	453.47	377.90	283.42	226.74	161.96	1.20
05877	8003VS	30	0.260	51.4	42.9	32.2	25.7	18.4	480.98	400.82	300.61	240.49	171.78	1.27	
	or	40	0.300	59.4	49.5	37.1	29.7	21.2	555.39	462.83	347.12	277.70	198.35	1.46	
	14385	AXI-8003	50	0.335	66.4	55.3	41.5	33.2	23.7	620.94	517.45	388.09	310.47	221.77	1.64
		(50 mesh)	60	0.367	72.7	60.6	45.5	36.4	26.0	680.21	566.84	425.13	340.11	242.93	1.79
05878	8004VS	30	0.346	68.6	57.2	42.9	34.3	24.5	641.31	534.42	400.82	320.65	229.04	1.69	
	or	40	0.400	79.2	66.0	49.5	39.6	28.3	740.52	617.10	462.83	370.26	264.47	1.95	
	14061	AXI-8004	50	0.447	88.5	73.8	55.3	44.3	31.6	827.93	689.94	517.45	413.96	295.69	2.18
		(50 mesh)	60	0.490	97.0	80.8	60.6	48.5	34.6	906.95	755.79	566.84	453.47	323.91	2.39
05879	8005VS	30	0.433	85.7	71.4	53.6	42.9	30.6	801.64	668.03	501.02	400.82	286.30	2.11	
	or	40	0.500	99.0	82.5	61.9	49.5	35.4	925.65	771.38	578.53	462.83	330.59	2.44	
	14386	AXI-8005	50	0.559	110.7	92.2	69.2	55.3	39.5	1034.91	862.42	646.82	517.45	369.61	2.73
		(50 mesh)	60	0.612	121.2	101.0	75.8	60.6	43.3	1133.69	944.74	708.55	566.84	404.89	2.99
05880	8006VS	30	0.520	102.9	85.7	64.3	51.4	36.7	961.96	801.64	601.23	480.98	343.56	2.54	
	or	40	0.600	118.8	99.0	74.3	59.4	42.4	1110.78	925.65	694.24	555.39	396.71	2.93	
	14387	AXI-8006	50	0.671	132.8	110.7	83.0	66.4	47.4	1241.89	1034.91	776.18	620.94	443.53	3.27
		(50 mesh)	60	0.735	145.5	121.2	90.9	72.7	52.0	1360.42	1133.69	850.26	680.21	485.87	3.59
05881	8008VS	30	0.693	137.2	114.3	85.7	68.6	49.0	1282.62	1068.85	801.64	641.31	458.08	3.38	
	(50 mesh)	40	0.800	158.4	132.0	99.0	79.2	56.6	1481.04	1234.20	925.65	740.52	528.94	3.90	
		50	0.894	177.1	147.6	110.7	88.5	63.2	1655.85	1379.88	1034.91	827.93	591.38	4.36	
		60	0.980	194.0	161.7	121.2	97.0	69.3	1813.90	1511.58	1133.69	906.95	647.82	4.78	
13674	MR8010	30	0.866	171.5	142.9	107.2	85.7	61.2	1603.27	1336.06	1002.05	801.64	572.60	4.23	
	(50 mesh)	40	1.000	198.0	165.0	123.8	99.0	70.7	1851.30	1542.75	1157.06	925.65	661.18	4.88	
		50	1.118	221.4	184.5	138.4	110.7	79.1	2069.82	1724.85	1293.64	1034.91	739.22	5.46	
		60	1.225	242.5	202.1	151.6	121.2	86.6	2267.37	1889.48	1417.11	1133.69	809.78	5.98	
14010	MR8015	30	1.299	257.2	214.3	160.8	128.6	91.9	2404.91	2004.09	1503.07	1202.45	858.90	6.34	
	(50 mesh)	40	1.500	297.0	247.5	185.6	148.5	106.1	2776.95	2314.13	1735.59	1388.48	991.77	7.32	
		50	1.677	332.1	276.7	207.5	166.0	118.6	3104.72	2587.27	1940.45	1552.36	1108.83	8.18	
		60	1.837	363.7	303.1	227.3	181.9	129.9	3401.06	2834.21	2125.66	1700.53	1214.66	8.96	
14195	MR8020	30	1.732	342.9	285.8	214.3	171.5	122.5	3206.55	2672.12	2004.09	1603.27	1145.19	8.45	
	(50 mesh)	40	2.000	396.0	330.0	247.5	198.0	141.4	3702.60	3085.50	2314.13	1851.30	1322.36	9.76	
		50	2.236	442.7	369.0	276.7	221.4	158.1	4139.63	3449.69	2587.27	2069.82	1478.44	10.91	
		60	2.449	485.0	404.2	303.1	242.5	173.2	4534.74	3778.95	2834.21	2267.37	1619.55	11.95	

Run a speed test in the area to be sprayed. The sprayer must be up to speed before starting the test run. To determine the speed mark off a distance as found on one of the tables. Push the sprayer over this distance carefully noting and recording the time to cover the distance. The speed traveled can be found for the specific distance and time to travel using the tables below.

After the nozzles have been individually checked and matched, the sprayer should be calibrated to determine the correct speed for the desired application volume.

**Table 3:** Time in Seconds to Travel Distance of:

	10	25	50	100	200
mph	(ft)	(ft)	(ft)	(ft)	(ft)
1	6.8	17.0	34.1	68.2	136.0
1.5	4.5	11.4	22.7	45.5	90.9
2	3.4	8.5	17.0	34.1	68.2
2.5	2.7	6.8	13.6	27.3	54.5
3	2.3	5.7	11.4	22.7	45.5
4	1.7	4.3	8.5	17.0	34.1
5	1.4	3.4	6.8	13.6	27.3
6	1.1	2.8	5.7	11.4	22.7

**Table 4:** Time in Seconds to Travel a Distance of:

	10	25	50	100	200
Km/h	(m)	(m)	(m)	(m)	(m)
1	36.0	90.0	180.0	360.0	720.0
1.5	24.0	60.0	120.0	240.0	480.0
2	18.0	45.0	90.0	180.0	360.0
2.5	14.4	36.0	72.0	144.0	288.0
3	12.0	30.0	60.0	120.0	240.0
4	9.0	22.5	45.0	90.0	180.0
5	7.2	18.0	36.0	72.0	144.0
6	6.0	15.0	30.0	60.0	120.0

**Note:** Tip pressure is usually less than the pressure at the pump. Losses occur in valves, hoses, etc. Always check the flow by the above calibration method.

## General Maintenance

### Cleaning

Sprayers need to be cleaned to prevent corrosion and cross contamination of chemicals. Trace amounts of one chemical can react with another or carry over to the next spraying and cause crop damage, especially with pesticides. Long exposures with even small amounts of some chemicals can damage sprayer components either by corrosion or gum deposits. If you spray crops that are very susceptible to injury from the last chemical used (ie vegetables, turf, and ornamentals) clean the unit especially well.

Always try to end the day with an empty tank; avoid contamination of water supplies and injury to plants or animals. Do not make puddles that might be accessible to children, pets, farm animals, or wildlife. Flush with clean water preferably after each day's operation. If you plan to use the same material over several days most chemicals may be kept in the tank overnight, labels on the chemical usually indicates which may not. Rinse the outside of the sprayer. Surfactants combined with chemicals, when they are compatible, will provide some cleaning action in the sprayer.

Some chemical combinations (especially if oil is used) may produce a putty type paste (buttering out) in the sprayer tank and components; flushing with water after each load may prevent an accumulation. If water alone does not dissolve and remove the buildup, add solvent, kerosene, or other low flammable solvent; allow paste to dissolve, then agitate and flush. Next, flush with detergent and finally with clean water. Check with your chemical agent.

Whenever pesticides are changed, or before sprayer storage, clean sprayers thoroughly with a cleaning solution. The solution used depends on the chemical to be removed from the sprayer. Check the chemical label for cleaning instructions.

First flush with water, then add the cleaning solution to the tank and thoroughly agitate before flushing. Always flush with clean water to remove the cleaning solution. Remove nozzle tips and screens; clean them in a strong detergent solution or kerosene, using a soft brush such as an old toothbrush. Never use a metal probe to clean the orifice of a spray tip!

Follow the same safety precautions during cleaning as for applications. Use a respirator, rubber gloves, or other protective gear as may be directed by label instructions.

If a nozzle becomes blocked, turn the sprayer off. Note that the spray lines could still be pressurized therefore prior to removing the cap on the nozzle body, proper safety equipment should be worn, (ie gloves, eye protection, etc).

## Sunshine

Many plastic sprayer parts are degraded by ultra violet light, especially the nozzle flow indicators. Store the sprayer in the shade to extend the length of service.

## Winterizing

After the sprayer is thoroughly cleaned, put 2-5 gallons (7-19 litres) of rust inhibitor or antifreeze in the tank prior to the final flushing to help prevent corrosion. As the water is pumped from the sprayer, the antifreeze will leave a protective coating on the inside of the tank, pump, and plumbing. Remove nozzle tips, screens and no-drip valves (if used) and store them in a can of light oil such as diesel fuel or kerosene to prevent corrosion. Close nozzle openings with tape to prevent dirt, insects, mice, or other contaminants from entering.

During the final cleaning, completely check the sprayer. Look at the hoses, clamps, connections, nozzle tips, and screens for needed replacements. Store the sprayer in a reasonably clean and dry building.

## Assembly

---

There is more than one way to successfully assemble your **Windfoil** sprayer. Following the outlined steps will help to ensure a simple, trouble free assembly. All assembly references to left and right are referring to the sprayer left and right when facing the rear of the sprayer. Two people are required to remove sprayer from carton, or for any general lifting of the equipment (ie lifting into transport mount).

### Front Wheel Installation

See General Assembly drawing for layout.

Locate four, (4) holes on the front of the sprayer, two, (2) to each side of the Windfoil logo.

Bolt the front wheel mount to these holes.

Slide front castor fork through castor bushing and insert cotter pins to secure.

Grease castor prior to use if required.

Install all three poly wheels.

### Handle attachment

Place the handle in position so that the tube is on the outside of the mounting plates.

Bolt handle into place.

Orient the handle so that the hose is to the right.

### Hose attachment

Attach hose from flow indicator to valve on handle with gear clamps as provided

### Last Check

Recheck all assembled parts for completeness and secure connections.

Locate the grease nipple on the front caster wheel and grease it.

Your sprayer is now ready for a wet test, to ensure complete operation.

## Operation

---

Ceramic insert tips are supplied with the **Windfoil WG series**; it can also use stainless steel, brass or plastic insert tips that give an actual 80° spray pattern.

Attach a supply hose to the camlock fitting on the control valve, located on the sprayer handle. The supply pressure of the fluid should be between 40 & 60 psi (3-4 bar). A rough estimate due to losses in the system is that when you have 45psi (3.2 bar) at the handle, you probably have 40 psi (3 bar) at the tips. Each of the balls in the spray monitor should raise to an equal level as the flow increases. If they are not equal the lower ball(s) indicated tips that are plugged or partially plugged. Check and clean the appropriate tip(s). If the balls are right at the top, the flow rate is too high for them. Replace them with the required balls for the tips (see the flow monitor page).

Test the unit using clear water on a firm surface such as asphalt or concrete before using spray solution. This will illustrate the effectiveness of the individual spray patterns.

## Maintenance

---

Cleaning and flushing with clear water after using.

Do not leave water in the unit at freezing temperatures. When storing the sprayer at freezing temperatures, run some windshield washer antifreeze through to prevent ice damage in the plastic parts.

Avoid storage of your sprayer in direct sunlight for prolonged periods. Certain plastic parts on the **Windfoil WG** are not UV resistant.

Keep the unit covered or stored indoors.

## Approximate Weight of Units

---

MODEL	Weight Lbs	Weight Kg
WG3	53.6	24.3
WG4	55.4	25.1
WG6	61.4	27.9

## Drawings and Replacement Parts

---

See the following pages for a parts breakdown and accessories for your unit.

# WG6 Parts Breakdown

Parts List			
ITEM	QTY	PART#	DESCRIPTION
1	1	14203	FRAME LP6
2	1	14028	CASTOR MOUNT ASSEMBLY
3	1	01588	CASTOR WHEEL, LP
4	1	14278	SHROUD WG6
5	1	13041L01	TANK MOUNT WALKER LEFT
6	1	13041R01	TANK MOUNT WALKER RIGHT
7	1	01654	AIRFOIL 86"
8	1	14208	FLEXISHIELD 9.625" x 151"
9	1	14206	FLEXISHIELD HANGER, 151"
10	1	14207	FLEXISHIELD HANGER, 44.625"
11	1	14209	FLEXISHIELD 9.625" x 44.625"
12	4	13478	STANDOFF, BACK (SHORT)
13	4	13479	STANDOFF, FRONT (LONG)
14	3	05459	BOLT, 5/8"x5.5", PLD
15	1	01051	NUT, NYLOCK, 5/8NC, PH
16	2	00965	PIN STL COTTER 3/16"x1-1/2"
17	1	00972	FTG, STL GREASE NIPPLE, 1/4NF
18	4	00966	BOLT, 1/4NCx2.5, PLD
19	28	00968	NUT, NYLOCK 1/4" PLD
20	8	05409	BOLT, 1/4NCx1.75, PLD
21	16	01154	BOLT, 1/4NCx3/4, PLD
22	2	14212	BUSHING IG 1.0x.875x.75" W/FLANGE
23	3	14281	CURTAIN SUPPORT LP FRONT
24	6	01156	SCREW TEK #12x1-1/4
25	2	13709	NUT, JAM 5/8NC, PH
26	2	01151	SCREW TEK #12x1
27	2	01056	PLUG, 1" SQ, PLASTIC
28	6	08754	WASHER, 1/4" FENDER
29	3	14475	WHEEL POLY ASSY 5/8ID
30	1	14529	HANDLE BAR ASSY H/IFD
31	4	01152	SCREW MACH #10-24x3/4, TRUSS

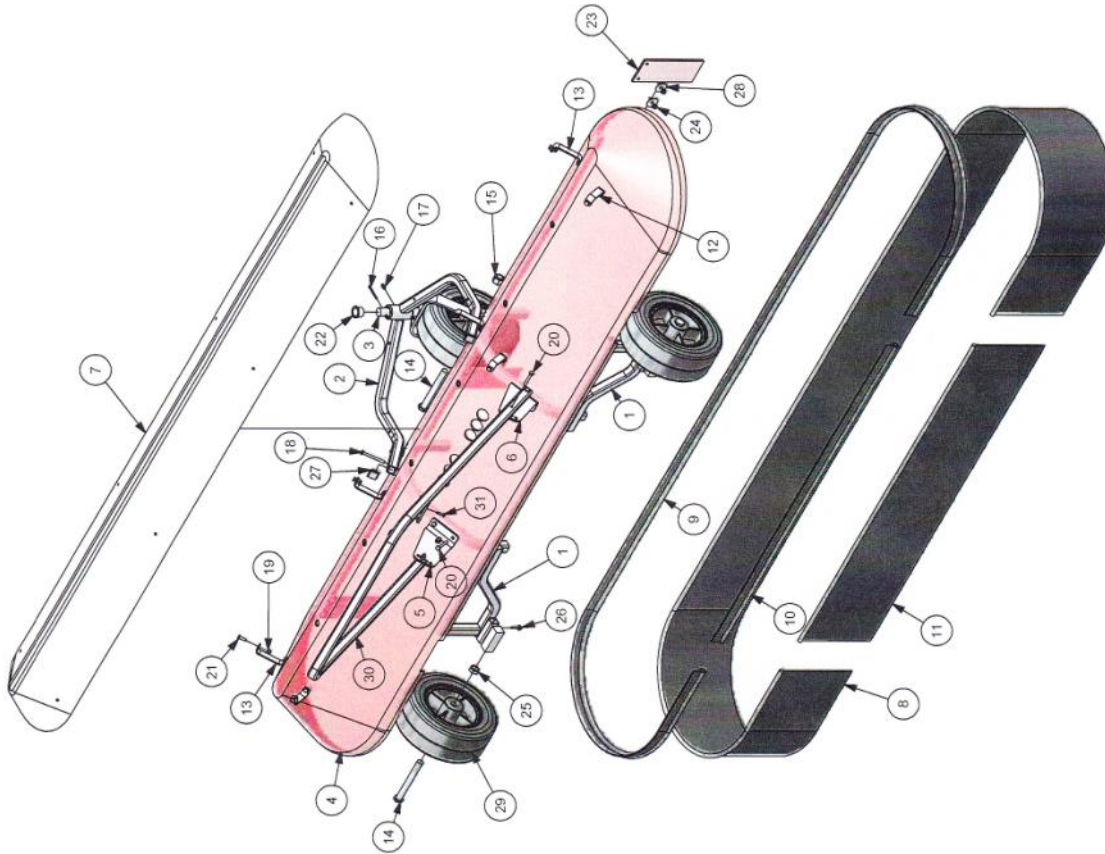

TO ATTACH SHROUD TO FRAME AND EXTRUSION USE:

QTY	PART#	DESCRIPTION
11	01156	SCREW TEK #12 x 1-1/4"
8	01152	SCREW TEK #10-24x3/4"
8	01153	NUT NYLOCK #10 PLD
4	05604	POP RIVET

DECALS:

2	01396	WINDFOIL LOGO
1	01397	ROGERS DECAL

DRAWN: MERV BLINSKI	
DATE:	
LOCATION:	
LOW PROFILE:	
REVISION #:	
SCALE: BEST FIT	
MATERIAL: A	
SIZE:	
ROGERS SPRAYERS INC.	
TITLE: WG6 ASSEMBLY	
DWG NO: WG6 Assembly	
SCALE: BEST FIT	
MATERIAL: A	
SIZE:	

# Plumbing Assembly WG & FG6

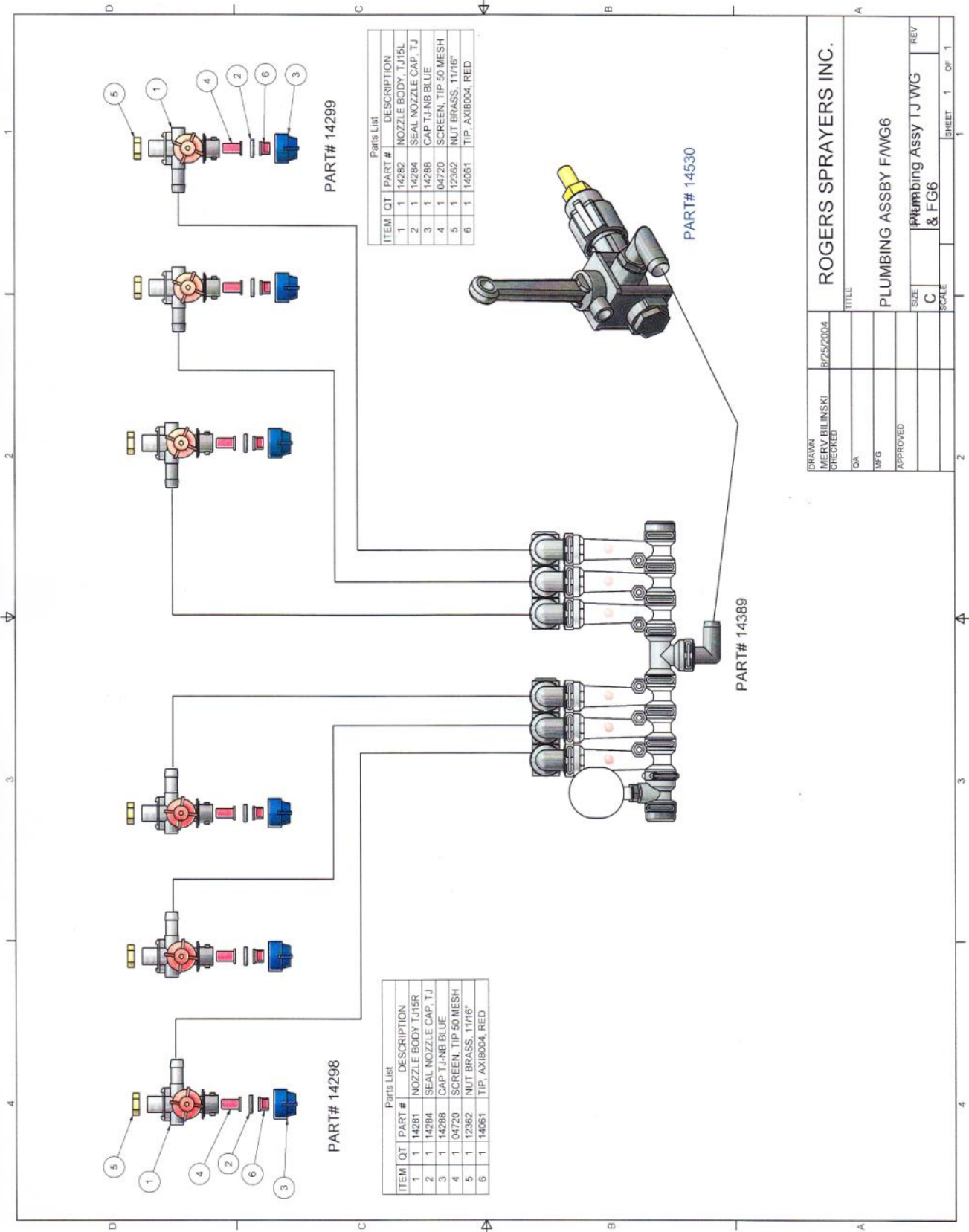

Parts List

ITEM	QT	PART #	DESCRIPTION
1	1	14282	NOZZLE BODY, T.J15L
2	1	14284	SEAL NOZZLE CAP, T.J
3	1	14288	CAP T.I.NB.BLUE
4	1	04720	SCREEN, TIP 50 MESH
5	1	12362	NUT BRASS, 11/16"
6	1	14061	TIP, AX180004, RED

Parts List

ITEM	QT	PART #	DESCRIPTION
1	1	14281	NOZZLE BODY T.J15R
2	1	14284	SEAL NOZZLE CAP, T.J
3	1	14288	CAP T.I.NB.BLUE
4	1	04720	SCREEN, TIP 50 MESH
5	1	12362	NUT BRASS, 11/16"
6	1	14061	TIP, AX180004, RED

DRAWN MERYL BILINSKI	DATE 8/25/2004	TITLE ROGERS SPRAYERS INC.
CHECKED		
QA		
MFG		PLUMBING ASSBY FAWG6
APPROVED		
SIZE C		PLUMBING ASSY T.J WG
SCALE		REV
SHEET 1	OF 1	

# Flowmonitor Assembly

ALTERNATE BALL YOU CAN USE  
IN YOUR FLOWINDICATOR  
FOR VARIOUS FLOWRATES  
AND COLORS OF CHEMICALS.

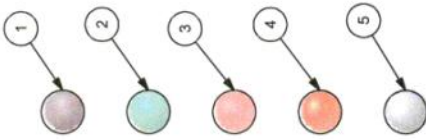

ITEM	QTY	PART#	DESCRIPTION
1	1	01118	BALL FI POLY 0.03-0.09 USGPM
2	1	01119	BALL FI POLY 0.05-0.18 USGPM
3	1	11990	BALL FI CELCON 0.09-0.3 USGPM
4	1	11965	BALL FI GLASS 0.31-0.72 USGPM
5	1	11991	BALL FI SSS 1/2" 0.31-1.3 USGPM

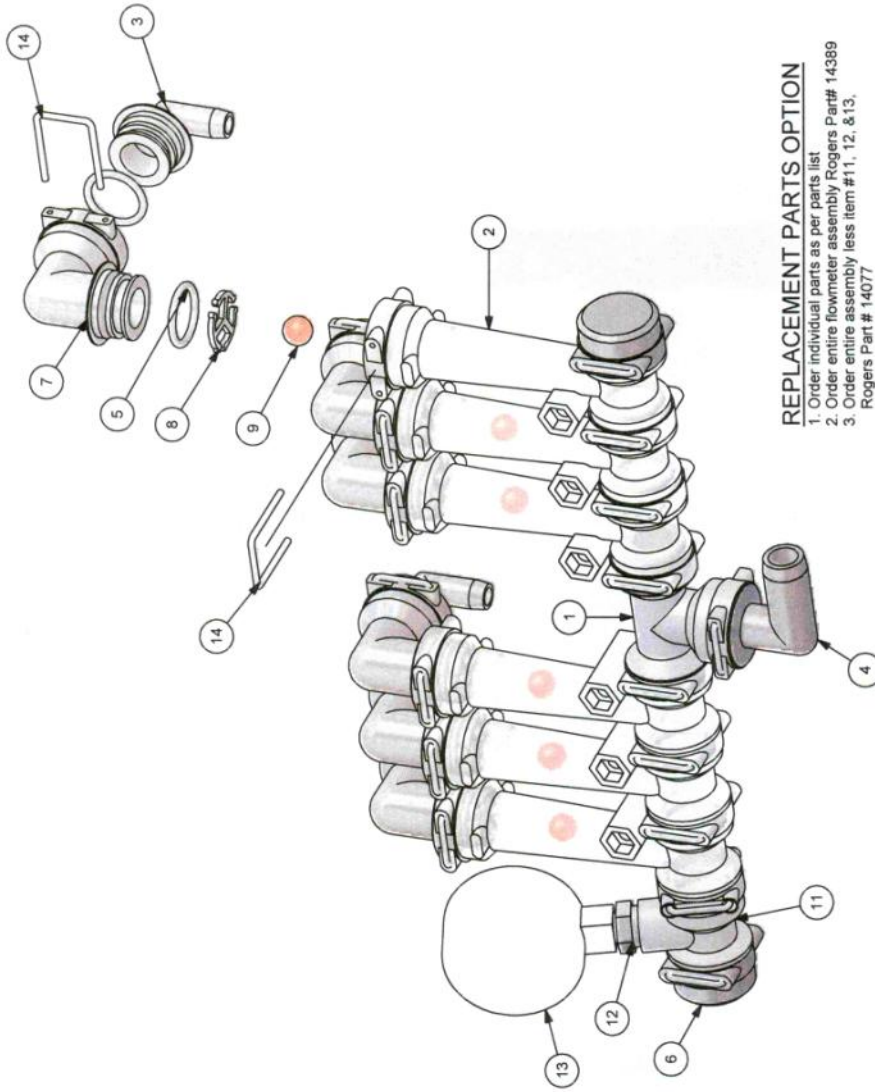

## REPLACEMENT PARTS OPTION

1. Order individual parts as per parts list.
2. Order entire flowmeter assembly Rogers Part# 14389
3. Order entire assembly less item #11, 12, &13, Rogers Part # 14077

ITEM	QTY	PART#	DESCRIPTION
1	1	13675	FTG POLY TEE ORC M/MF
2	6	00889	FLOWMONITOR ORC BODY
3	6	00906	FTG POLY ELB MORC x 1/2HB
4	1	00905	FTG POLY ELB MORC x 3/4HB
5	22	11984	O-RING ORC
6	2	00909	FTG POLY ORC CAP
7	6	01115	FTG POLY ELB ST MORC x FORC
8	6	11989	ORC BALL RETAINER
9	6	11965	BALL FI GLASS 0.31-0.72 USGPM
11	1	14244	FTG POLY TEE ORC M/F/FNPT 3/8"
12	1	05679	FTG POLY RDCR 3/8MNPTx1/4FNPT
13	1	01281	PRESSURE GAUGE
14	22	11976	ORC CLIP

DRAWN:	MERV BILINSKI	ROGERS SPRAYERS INC.
DATE:		
DESIGNED:		
LOCATION:		
REVISED:		
TITLE:	FLOWINDICATOR WG6 w/GAUGE	
DWG NO:	14389	
SCALE:	BEST FIT	MATERIAL:
		SIZE:
		A

## Valve Assembly G-Series Part # 14530

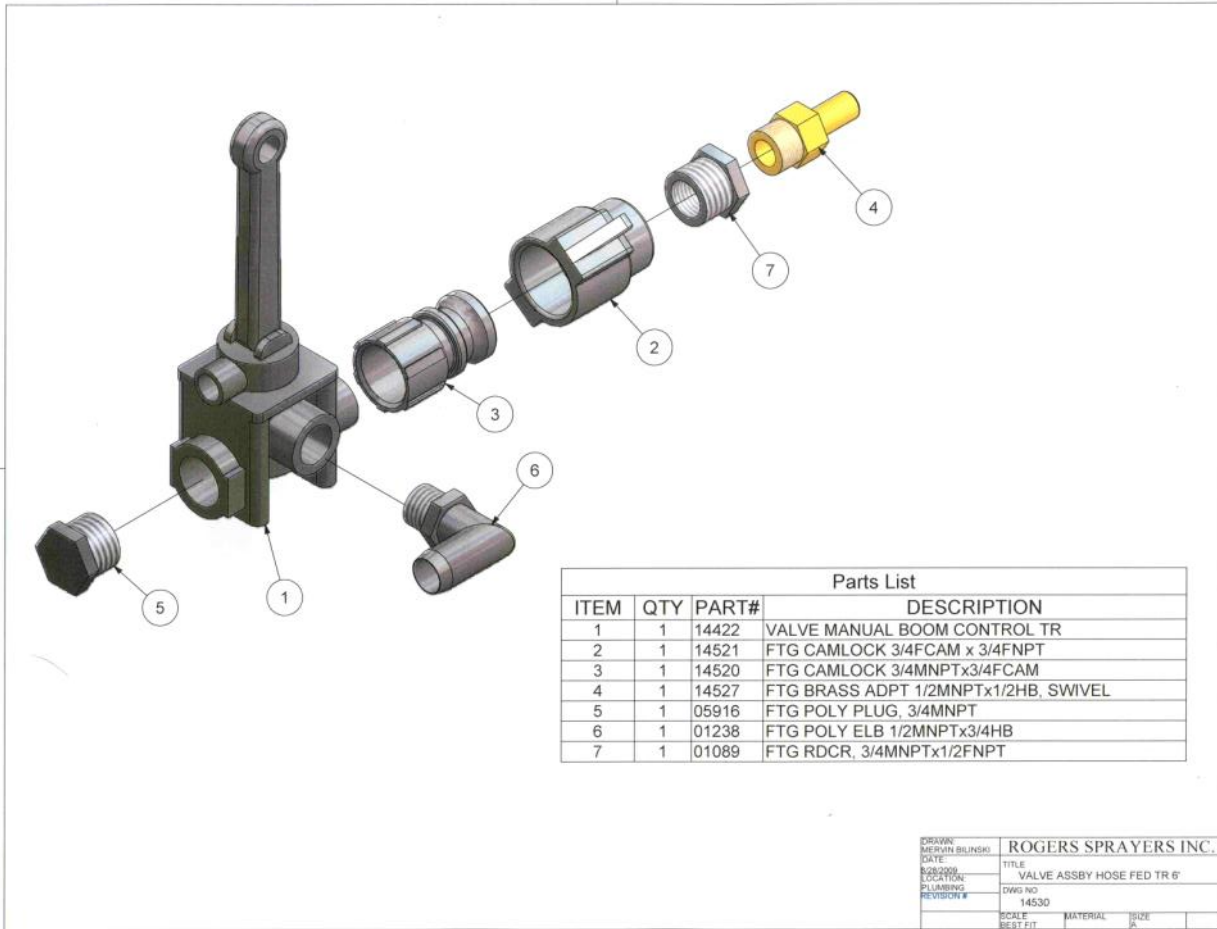

## F111 Tow Hitch

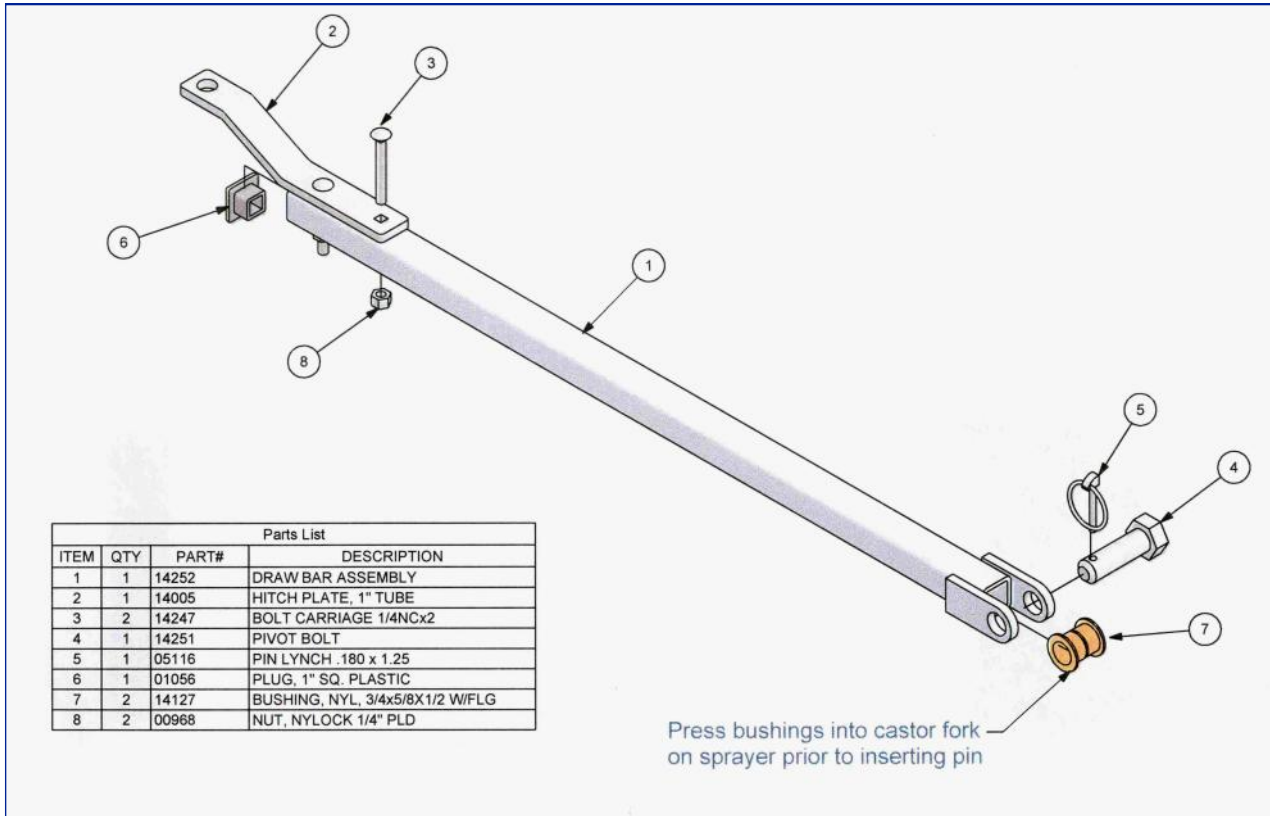

# EC Declaration of Conformity

WE,

Rogers Sprayers Inc.  
141 - 105th St East  
Saskatoon, Saskatchewan, S7N 1Z2  
Canada

## **declare that the following products**

Machine Type: Rear mounted spray boom

Model: WGF11, FGF11, WA5000E, WA5000, FA5000E, FA5000

Machine Type: Pedestrian Boom

Model: WG3, WG4, WG6, FG3, FG4, FG5

Machine Type: Pedestrian Spray Boom

Model: WE3, WE4, WE6, FE3, FE4, FE6

## **is in conformity with the provisions of the following European Directive(s)**

Directive	Number	Certification Method
Machinery Directive	98/37/EC	Self-Certification
Machinery Directive	2006/42/EC	Self-Certification

## **And the following Standard:**

SS-EN 907  
EN ISO 4254-1:2009  
EN ISO 4254-6:2009

The original copy of this document is kept at Rogers Sprayers Inc. with copies of the relevant test data and certificates, which constitute the required technical file for self declaration.

Place of declaration: Saskatoon, Saskatchewan, Canada

Date of declaration: May 3, 2011



Name: Mervin Bilinski, P. Eng.

Title: President

Rogers Sprayers Inc.



## **ROGERS SPRAYERS INC.**

141 - 105th Street East  
Saskatoon, SK S7N 1Z2  
Canada

Phone: (306) 975-0500  
Fax: (306) 975-0499  
Email: [info@rogerssprayers.com](mailto:info@rogerssprayers.com)  
Web: [www.rogerssprayers.com](http://www.rogerssprayers.com)